

Premium Preparation 1600 mm Meat & Fish Processing/ Washing Table

ITEM # _____

MODEL # _____

NAME # _____

SIS # _____

AIA # _____

132963 (TLC1600EN)

 Meat and Fish Processing/
 Washing Table with
 perforated and removable
 Plates, knife holder,
 polythene cutting board,
 drain, scraping hole and
 upstand, 1600mm

Short Form Specification

Item No. _____

50mm high worktop in 304 AISI stainless steel, 1,5mm in thickness, sound-deadened, anti-drip edges and welded corners. Integral radiused rear upstand, h=100mm with 10mm radius. All-round apron. Round section legs and feet in 304 AISI stainless steel, 50mm in diameter. N.1 polythene cutting board 1130x225x25h mm, drain and waste scraping hole on front.

Main Features

- Sturdiness, stability and reliability of table accurately tested.

Construction

- Table can be equipped with a mobile bin with lid for waste disposal (optional accessory).
- Round section legs with feet in 304 AISI stainless steel, 50 mm in diameter, adjustable in height by +0/-40 mm.
- Unit features a 20 mm deep recessed surface, a polythene cutting board and a scraping hole on the front, perforated and sectionated removable tops, an easily removable GN liquid container and a knife holder. Knife sanitizer can be supplied as optional.

Optional Accessories

- Single drawer GN 1/1, 400mm PNC 855280
- Single drawer, 600mm PNC 855281
- Lower shelf for 1600mm for units PNC 855284
- Set of 4 wheels (2 with brake) d. 100mm PNC 855288
- 3-sided underframe for 1600mm tables PNC 855292
- Additional drawer, 600mm (to set up a chest of 2, 3, 4 drawers) PNC 855295
- Additional drawer GN 1/1, 400mm (to set up a chest of 2, 3, 4 drawers) PNC 855298
- Elbow operated mixer tap with spout 3/4", single hole PNC 855322
- Elbow operated mixer tap with short spout 3/4", single hole PNC 855323
- Foot operated mixer tap (hot and cold) with spout 3/4" PNC 855328

APPROVAL: _____

Front

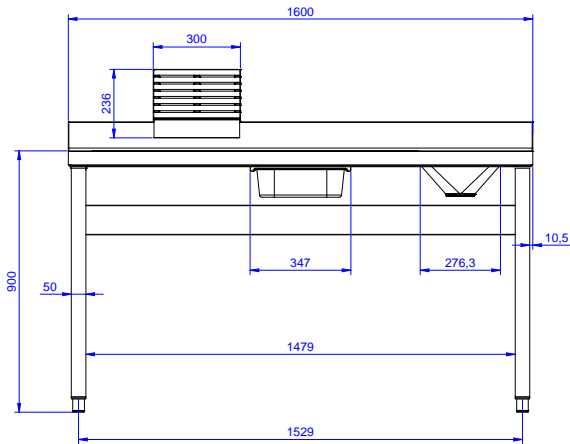

Side

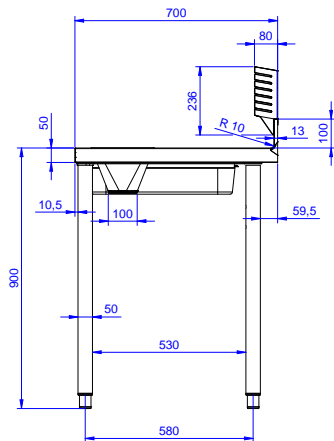

D = Drain

Top

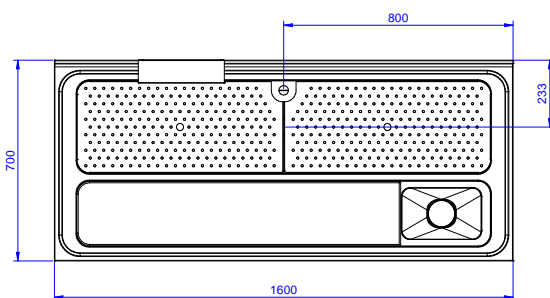
Key Information:

External dimensions, Width:	
132963 (TLC1600EN)	1600 mm
External dimensions, Depth:	700 mm
External dimensions, Height:	1000 mm
Upstand Dimensions, Height:	100 mm
Upstand Dimensions, Depth:	13 mm
Upstand Dimensions, Radius:	R=10
Bowls number	1
Bowl dimensions	1670x320xH180
Worktop thickness:	50 mm
Net weight:	60 kg